

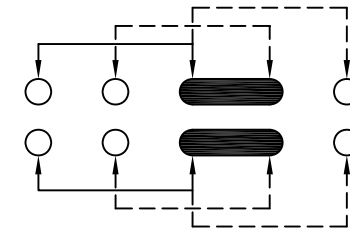

CAD FILE:

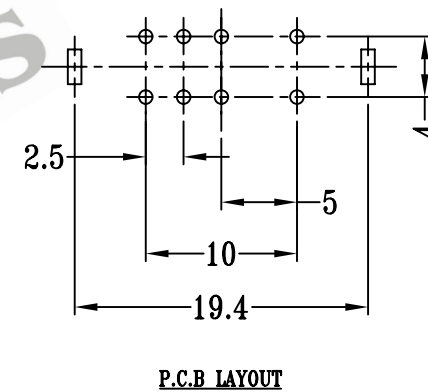
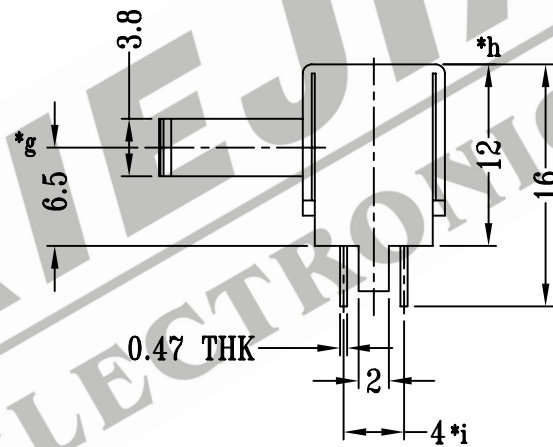
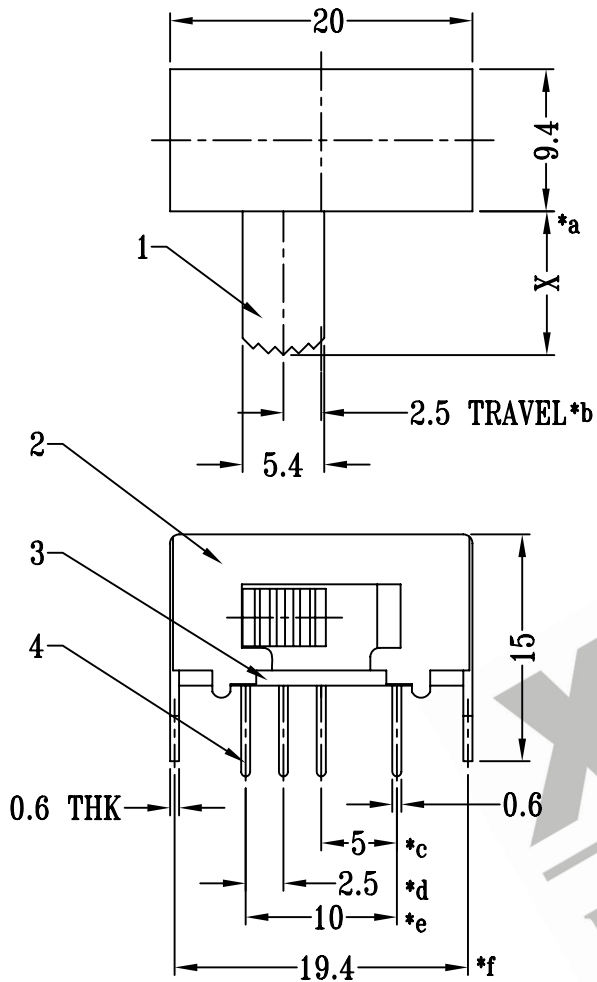

SCHEMATIC (SHORTING)

注:带*表示关键尺寸(9个)

8					TOLERANCE	SHENZHEN XIEJIA ELECTRONICS CO.,LTD.				
7	STEEL STRIP	STEEL	1	NATURAL	UNLESS SPECIFIED					
6	SPRING	STAINLESS STEEL	1	TEMPER	WITHIN: 1.5 ±0.1mm	ISSUE	DATE	DESCRIPTIONS		APPD
5	CONTACT (CLIP)	PBS STRIP	2	Ag PLATED	OVER: 1.5 ±0.2mm					
4	TERMINAL	BRASS STRIP	8	Ag PLATED OVER Ni PLATED	TITLE: HORIZONTAL SLIDE SWITCH		UNIT : MM	DRWG NO.:XJ-DR-SK23E01-00		
3	TERMINAL BASE	PHENOLIC RESIN	1	NATURAL	MODEL: SK-23E01		SCALE: 2:1	DWN	ZHOUYU	2007-11-26
2	FRAME	STEEL STRIP	1	Ni PLATED				CHK'D	FANGYING	2007-11-26
1	KNOB	POM	1	BLACK	ALL MATERIALS MUST BE COMPLIANT TO ROHS		APPD	KANGXINAN	2007-11-26	
NO.	PART NAME	MATERIAL	QTY	FINISHING						